

USF207 STOKOTA 6as semi

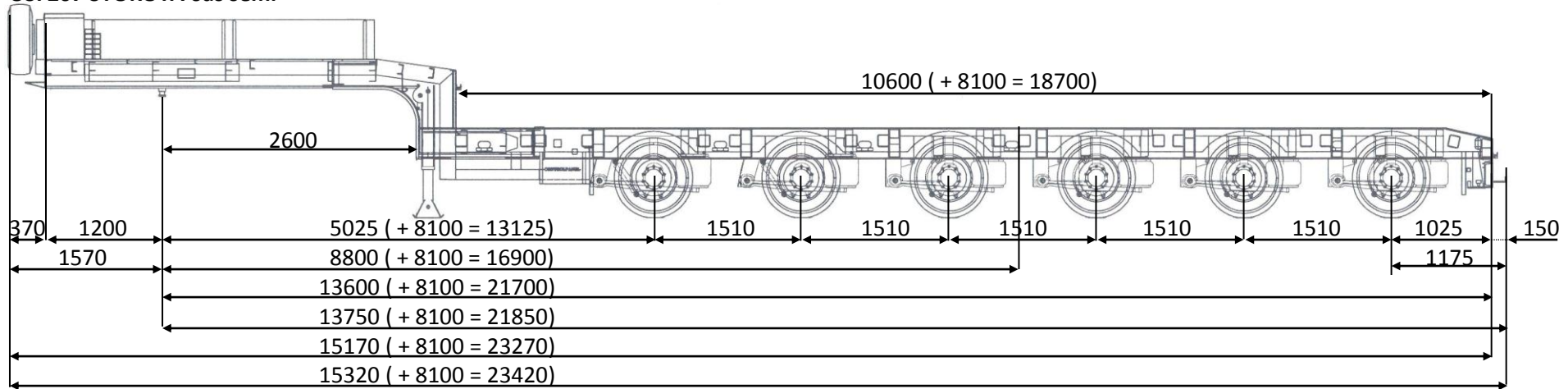

Operationeel gewicht: 4585 kg
 Documenten gewicht: 4980 kg

16104 kg / 6 = 2684 kg
 14400 kg / 6 = 2400 kg

totaal 20689 kg
 totaal 19380 kg

Merk: Stokota

Type: S6U.H5.01

Serienummer: YA9UKS61008191028

Operationeel totaal gewicht: 20689 kg

Documenten totaal gewicht: 19380 kg

	Koppelpen	laadvloer
Rij hoogte	1300 mm	930 mm.
Min. hoogte:	/	??? mm.
Max. hoogte:	/	??? mm.

Deel	1	2	3	4	5	6	7	8	9	10	11	12	13	14
UD	300	600	1300	1600	1800	2300	2450	2800	3300	3800	4300	4800	5350	5900
Deel	15	16	17	18	19									
UD	6400	6900	7400	7900	8100									

